

Mobile portaoggetti 2 ante scorrevoli 2-sliding door wardrobe unit

Misure / Measures

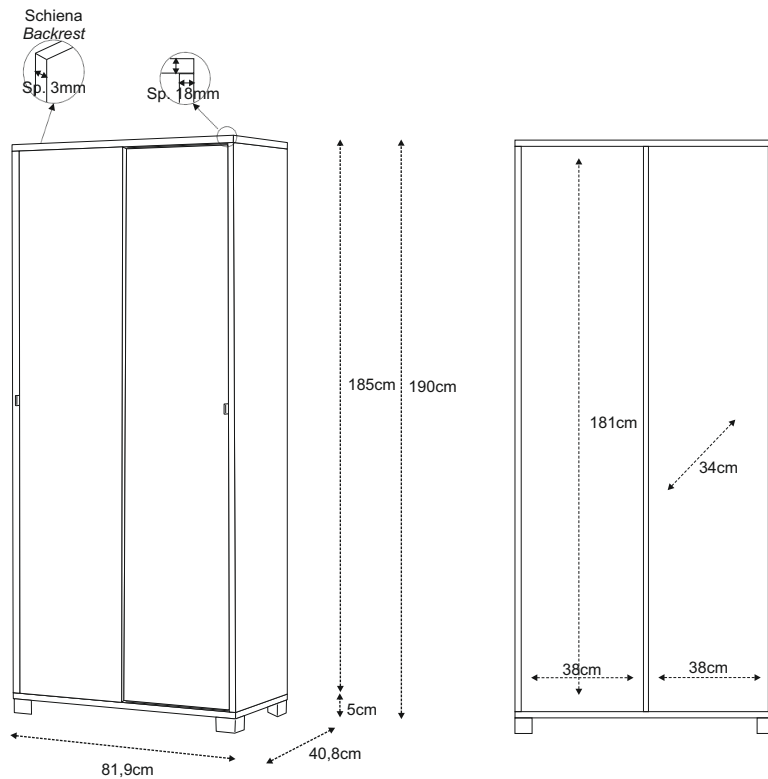

Dettagli / Details

- Struttura materiale in truciolare nobilitato
- Maniglie in zama
- Piedini verniciati cromo satinato
- Contiene: 8 ripiani regolabili in altezza
- Mobile in kit
- *Material structure in engineered wood*
- *Zama handles*
- *Chrome-plated feet*
- *Inside: 8 adjustable shelves*
- *Kit furniture*

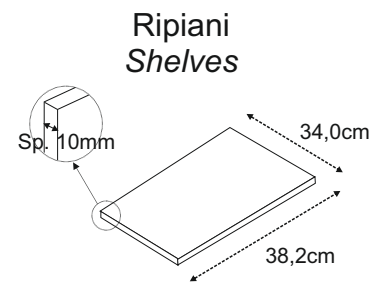

Componenti / Elements

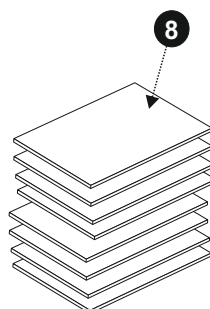
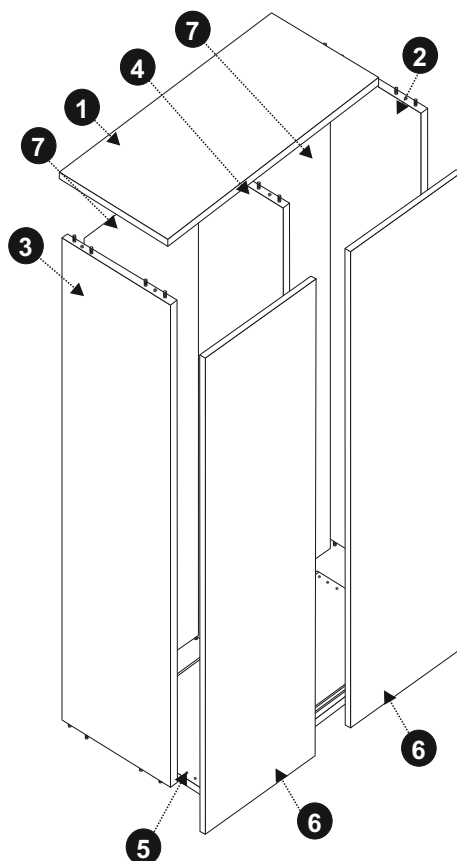

Pos.	Pezzi / Pcs	Descrizione / Description
1	1	Coperchio (819 x 408 x 18mm) <i>Top (819 x 408 x 18mm)</i>
2	1	Fianco dx (1813 x 408 x 18mm) <i>Rh Side (1813 x 408 x 18mm)</i>
3	1	Fianco sx (1813 x 408 x 18mm) <i>Lh Side (1813 x 408 x 18mm)</i>
4	1	Tramezza (1813 x 356 x 16mm) <i>Partition Side (1813 x 356 x 16mm)</i>
5	1	Base (819 x 408 x 18mm) <i>Base (819 x 408 x 18mm)</i>
6	2	Anta (1808 x 392,5 x 16mm) <i>Door (1808 x 392,5 x 16mm)</i>
7	2	Schiena (1829 x 395 x 3mm) <i>Backrest (1829 x 395 x 3mm)</i>
8	8	Ripiani (382 x 340 x 10mm) <i>Shelves (382 x 340 x 10mm)</i>